

## Welcome

Dear Stratos 200 pilot, thank you for choosing the XLPower Stratos 200. This helicopter is designed as a high-precision remote-controlled helicopter, combining compact engineering design with the flight experience of larger machines. Careful assembly and inspection are crucial, as even very small setting errors (such as a deviation of 0.02 millimeters) can significantly affect flight performance. We hope you see the assembly process as a part of enjoying this hobby.

- Guide to Threadlock use -
- Items marked Blue: Medium-strength threadlock (e.g. Loctite 243), pre-applied at the factory
  - Exception: Tail blade screws (M1.6-8) and tail boom clamp screws (M2x20) require application on model assembly. \*WHEN INSTALLING TAIL BLADE SCREWS APPLY COMPOUND TO FEMALE THREADS IN MOTOR! (Do not allow threadlock compound to come in contact with plastic blades)
  - Items marked Green: Bearing retaining compound (e.g. Loctite 638), pre-applied at the factory



Page1

Specification	Details
Size(L* W *H)	444 x 90 x 132 mm
Weight	264g(No Gyro and Battery)
Motor / ESC	Hobbywing Platinum V5 (integrated) Supports DShot150 / 300 / 600
Servos	DS4208 (4.2 kg · 0.08 s @8.4V)
Main Blade / Tail Blade:	195 mm / 45 mm
Gyro(not included)	3-axis or above, with tail motor mode
Transmitter/Receiver(not included)	6 channels or above
Battery (not included)	3S 750mAh / 4S 650mAh (XT30) Max size: 70 x 32 x 24 mm

Note: The recommended battery, gyro, and radio/receiver are not included in the standard kit and must be provided by the user.

Page3

## STEP 1

### Landing Gear Installation

1. Remove the canopy.
2. Align the holes on the bottom of the frame with the landing gear.
3. Make sure the front and rear orientation is correct.
4. Secure with 4 self-tapping M2x5 screws. Do not overtighten and strip the threads.

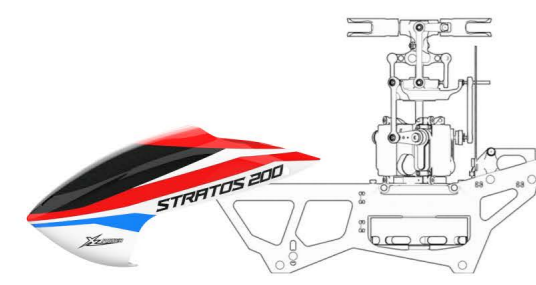

Page5

## STEP 3

### Gyro Installation

Use gyro-specific double-sided tape to mount the gyro. Keep the gyro level and parallel to the frame. All preinstalled wires are color-coded; connect them as follows:

Port	Wire Connection
ESC	Black / Red / White
TAIL	Blue signal wire
RPM	Green signal wire
TELE	Yellow signal wire
S1 / S2 / S3	Rear / Left / Right servo (viewed from the tail)

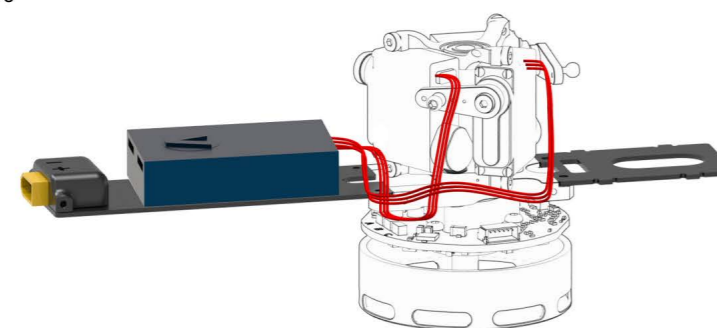

Page7

## STEP 5

### Main Blade and Tail Blade Installation

#### Tail Blade Installation

1. Use 2 M1.6x8 screws plus washers to secure the tail blade.
2. Apply a small amount of 243 thread-lock.
3. Make sure the direction is correct, with airflow directed to the right.

#### Main Blade Installation:

1. Insert the main blades and secure them with M2x12 screws and lock nuts.
2. Adjust so there is no vertical play, but the blades can pivot smoothly left and right.
3. The printed side of the blade should face upward.

▲ Note: The main blade tension should be moderate, with slight damping resistance. If the blades are too tight or too loose, flight performance will be negatively affected.

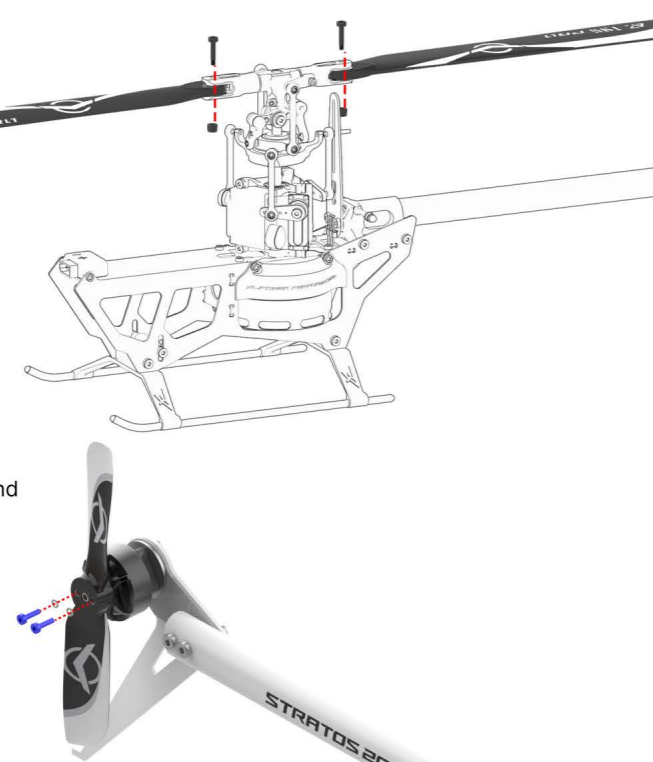

Page9

## Important Safety Notice

### WARNING: THE STRATOS 200 IS NOT A TOY

The Stratos 200 is a precision flying machine intended for experienced and responsible operation. Extreme performance means higher operating requirements. Improper assembly, setup, or use may result in serious property damage, severe personal injury, or death. By assembling or operating this product, the user acknowledges and fully accepts all associated risks.

### Flight Safety Rules

- **Legal Airspace:** Fly only in legal, open areas or at approved RC model flying fields. Never operate above crowds or in densely built-up areas.
- **Pre-Flight Checklist:** Before every flight, verify radio communication and confirm all rotating parts are fully secure.
- **Safety Distance:** Stay clear of high-speed rotors; they carry immense kinetic energy.
- **Assembly Precision:** Strictly follow this manual's recommendations for assembly accuracy and thread-lock usage instructions.

### Liability and Responsibility

XLPOWER is not responsible for any special, indirect, or consequential damages, such as loss of profit or business loss arising from the use of this product. Under no circumstances will XLPOWER's liability exceed the purchase price of the product. By using, installing, or assembling this product, the user accepts all resulting responsibility. If you do not agree to accept these responsibilities, please immediately return the product to the place of purchase in new and unused condition.

## Box Contents

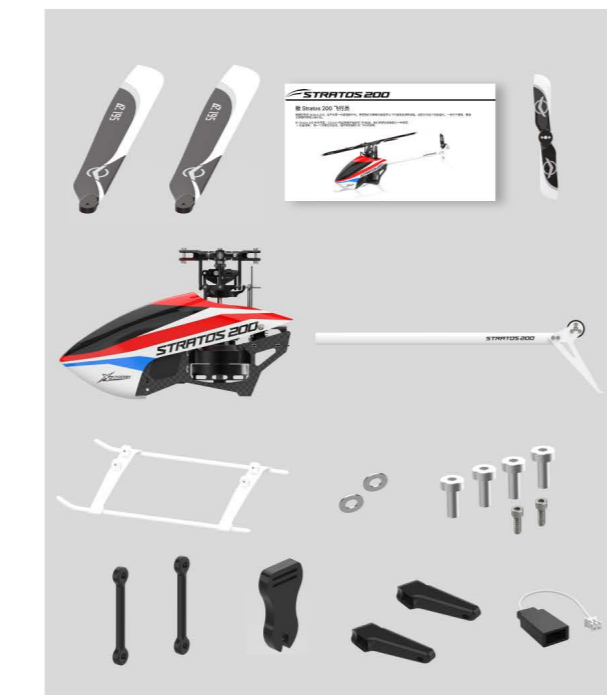

Page2

## STEP 2

### Tail Boom Assembly Installation

1. Align the tail boom with the boom mount in the correct top/bottom orientation.
2. Push it in fully and confirm the internal connector is connected.
3. Make sure the front and rear orientation is correct.
4. Secure with 4 self-tapping M2x5 screws. Do not overtighten and strip the threads.

#### IMPORTANT DIRECTION CHECK

After installation, confirm the tail motor rotation direction is correct, with airflow blowing to the right.

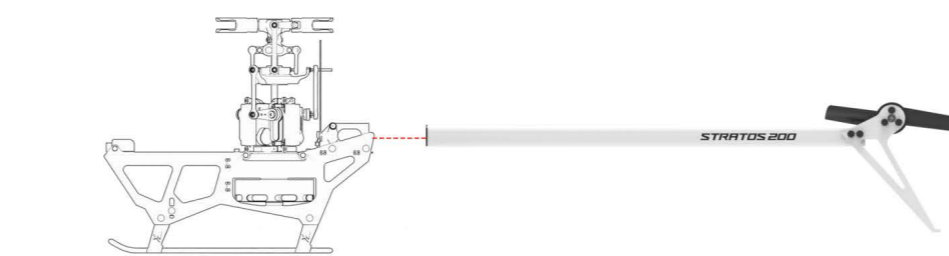

Page6

## STEP 4

### Battery Installation

1. Align the battery with the battery tray opening.
2. Adjust the output wire direction according to wire length; if the wires are short, route them upward.
3. Push the battery fully into place.
4. Loosen the bottom M2 screw and adjust the aluminum post so it firmly holds the battery in place; apply a small amount of 243 thread-lock.
5. Tighten the screw and ensure the battery does not move.



Page8

## STEP 6

### Canopy Installation

1. **Bottom positioning:** Push the canopy forward so that the front edge hooks under the landing gear.
2. **Side locking:** Attach the rubber grommets on both sides to the canopy's aluminum posts.

#### ▲ Pre-Flight Checklist

Before every takeoff, verify the following:

- Servo directions are moving correctly according to transmitter inputs.
- Tail motor direction is correct, with airflow blowing to the right.
- Main blade pitch direction is correct.
- Battery is firmly secured.
- Tail boom is securely locked with no play.
- All screws are tightened correctly and thread-lock has cured.
- Radio system is functioning properly with a solid connection.



Snap onto the lower landing gear

Lock to the Aluminum Standoff

Page10

## Main rotor head assembly

Note: All part numbers are prefixed with "XL20"

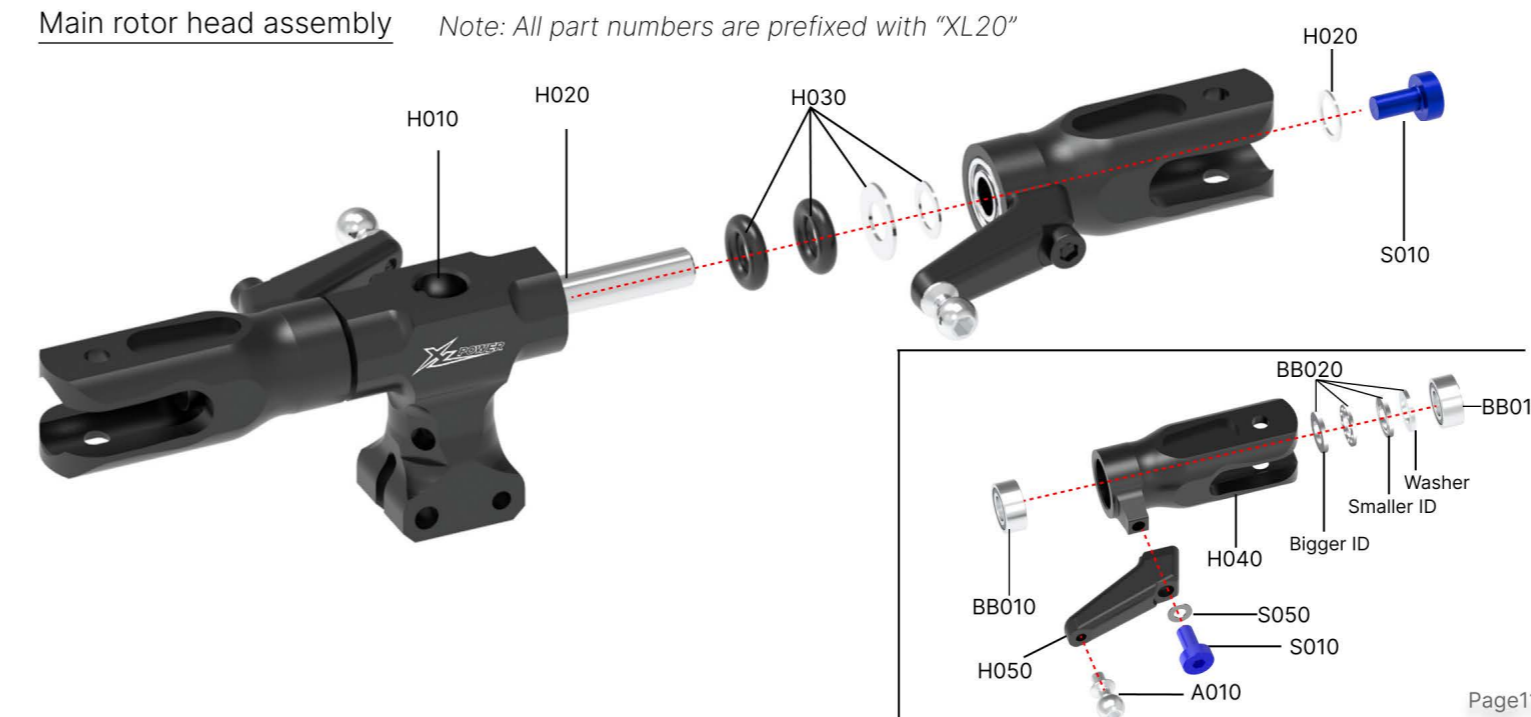

Page11

## Swashplate assembly

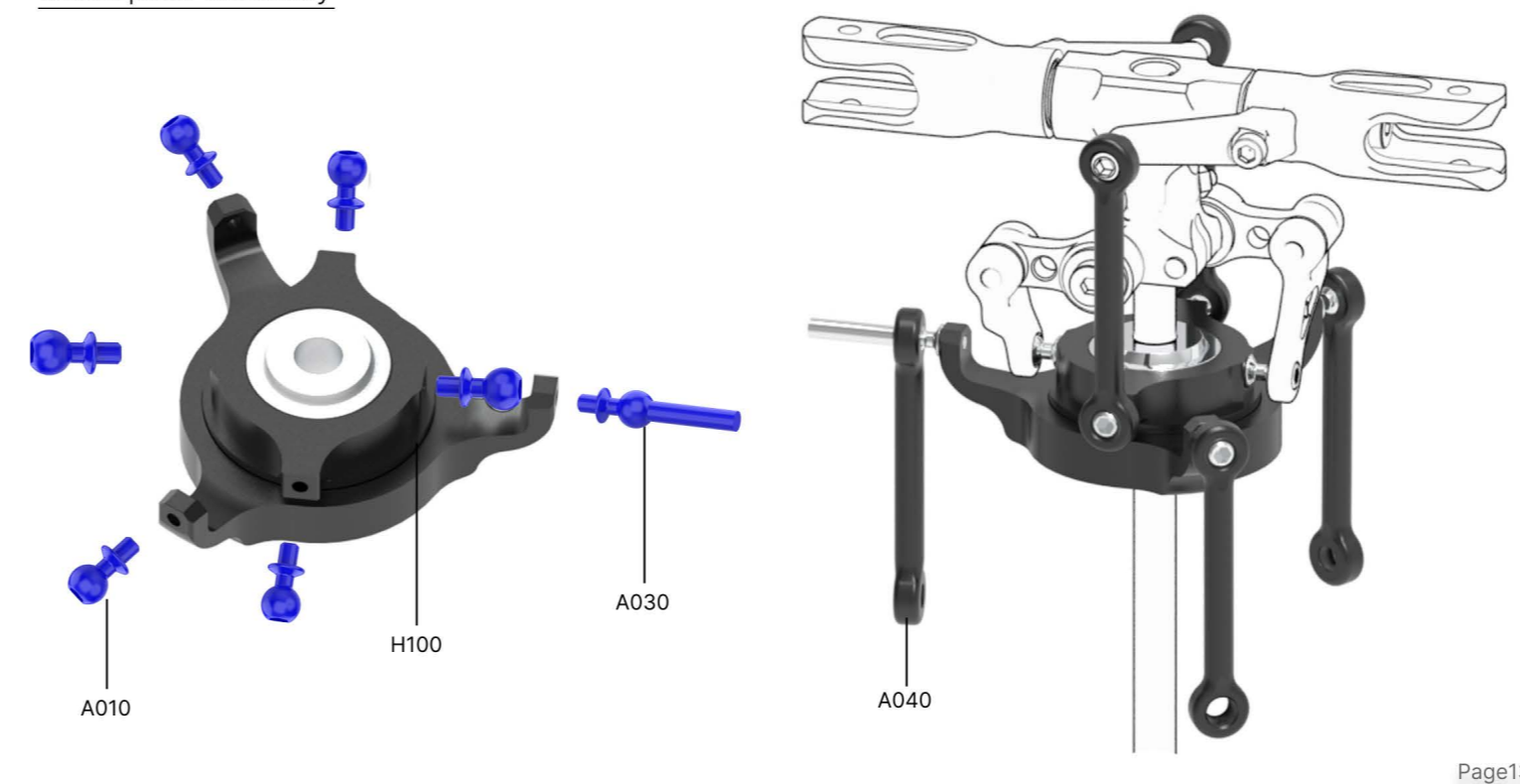

Page13

## Gyro plate assembly

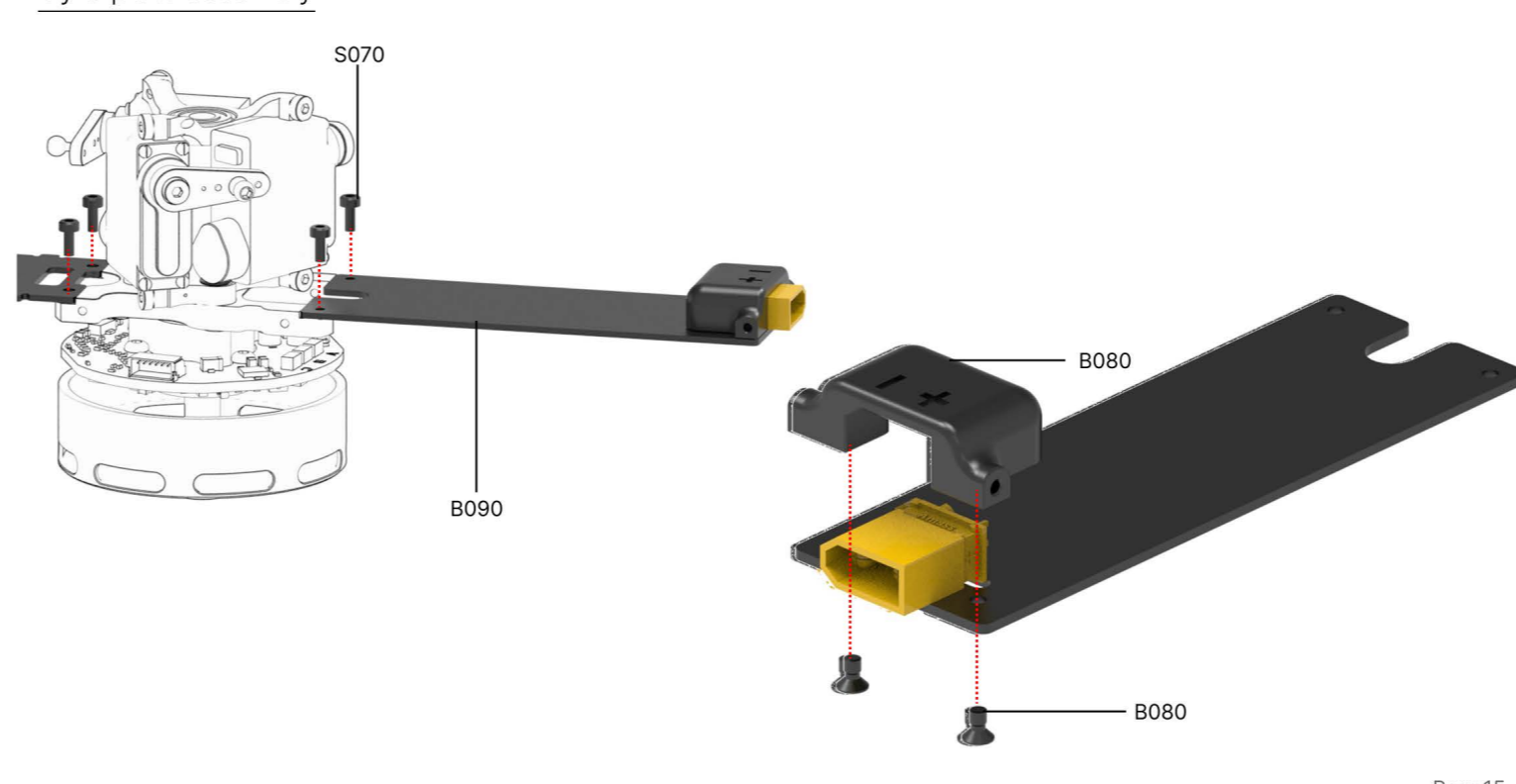

Page15

## Frame assembly

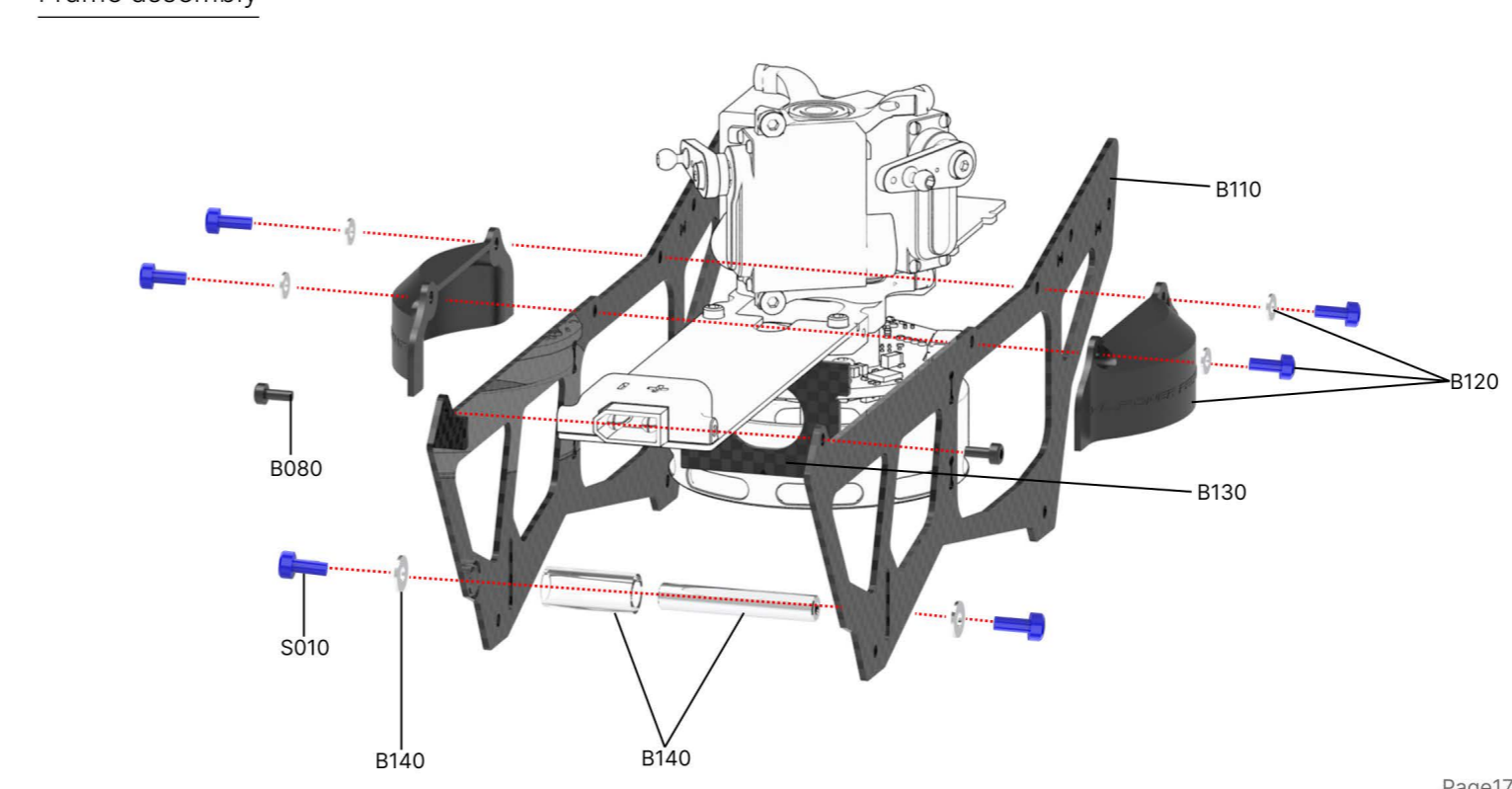

Page17

## Main head assembly

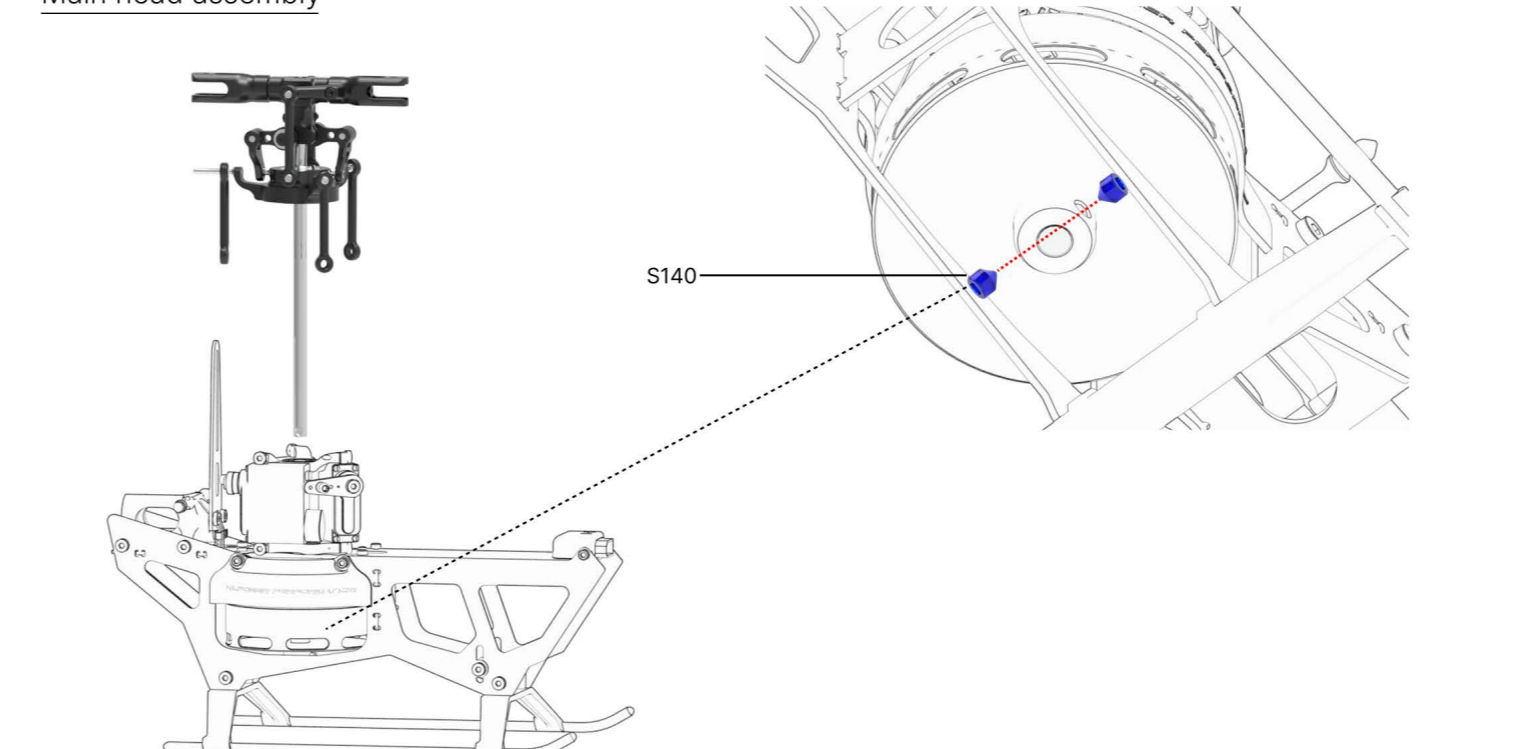

Page19

## Main shaft assembly

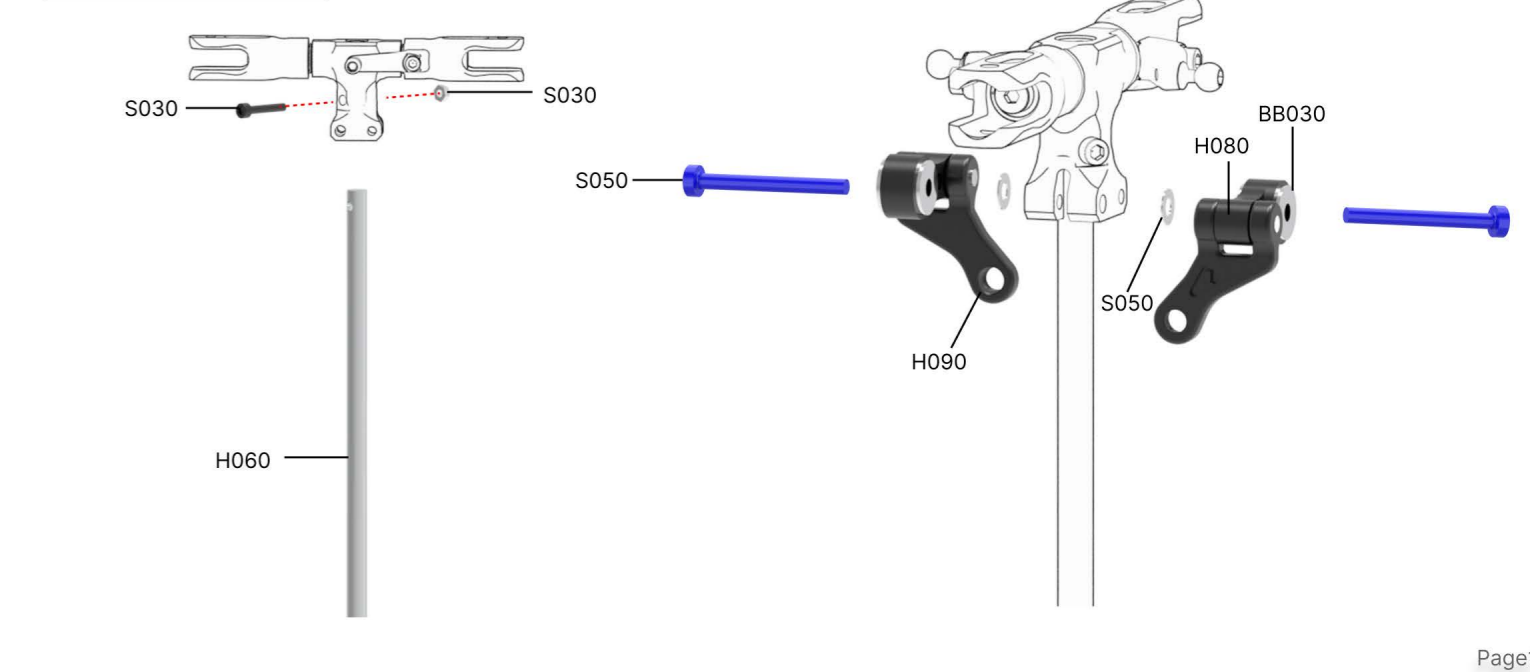

Page12

## Main shaft block and motor and servo assembly

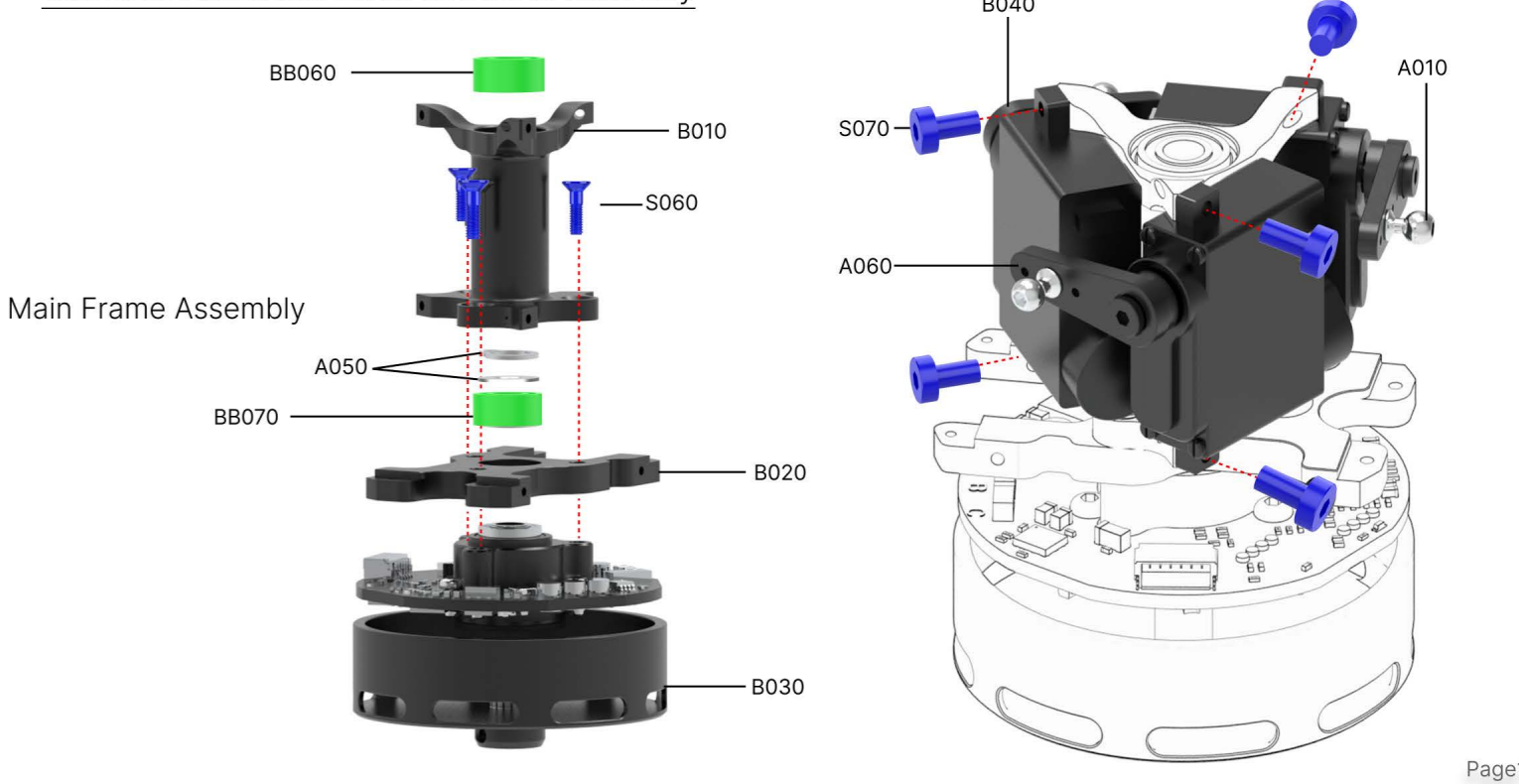

Page14

## Anti rotation guide assembly

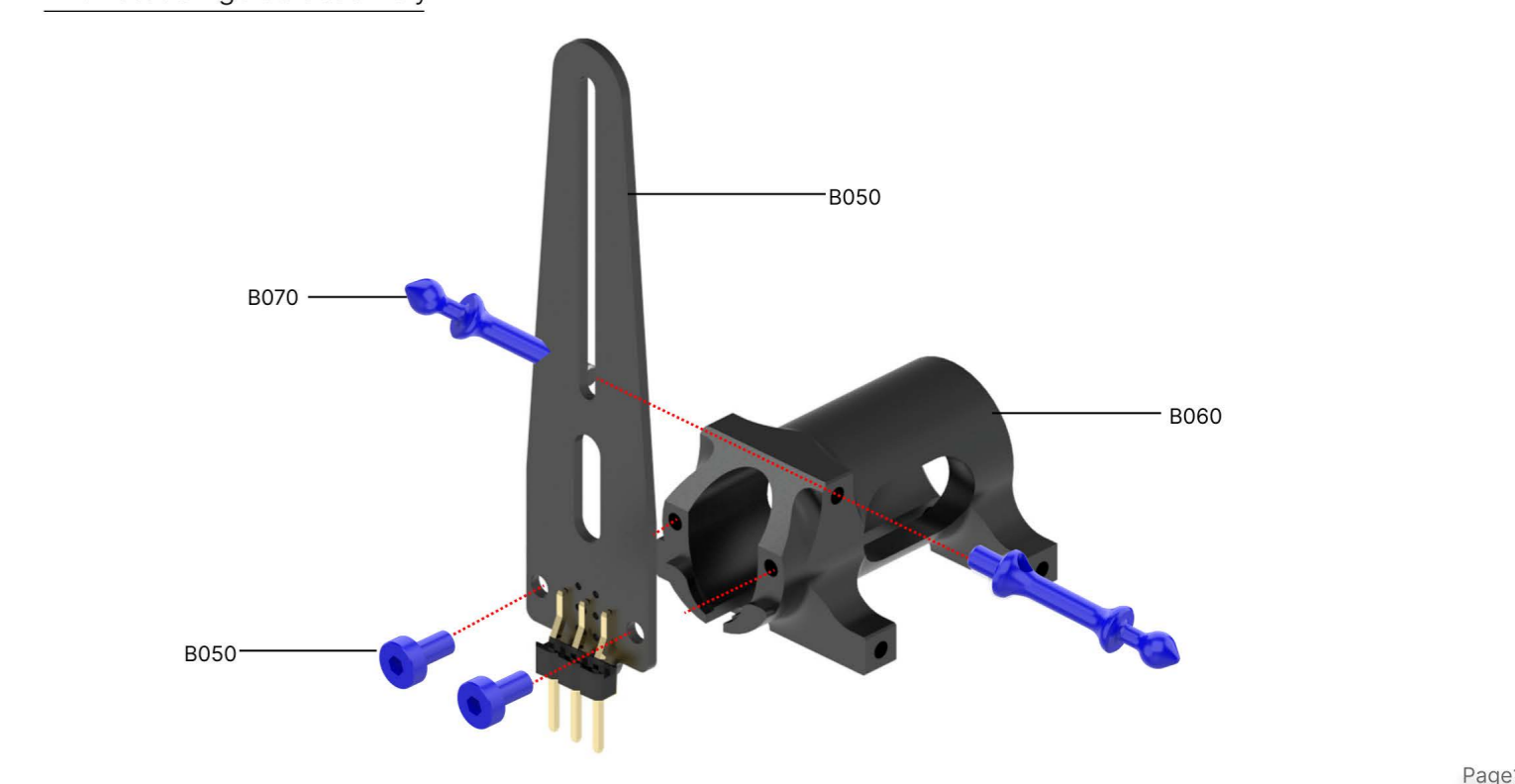

Page16

## Tail boom clamp assembly

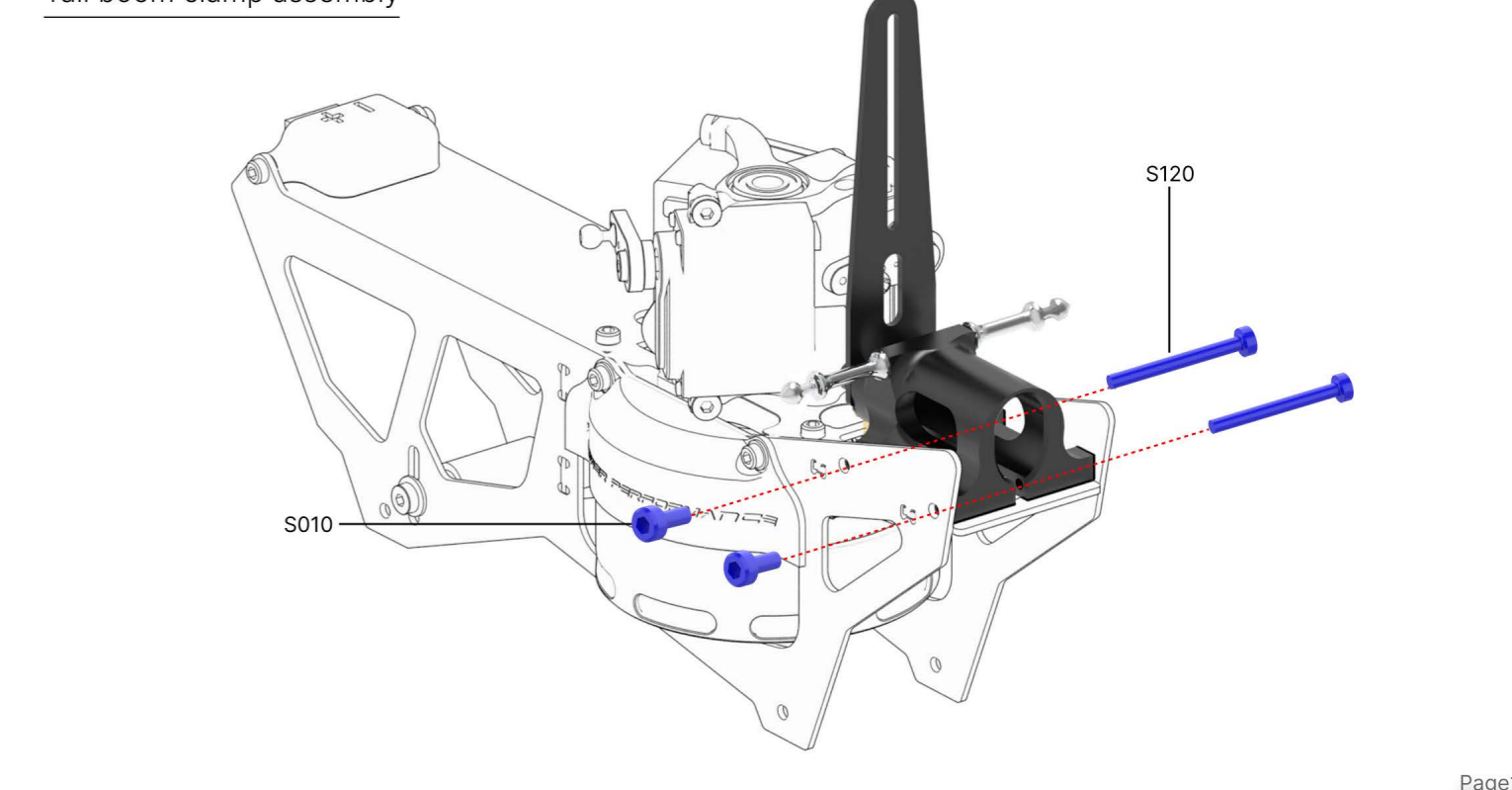





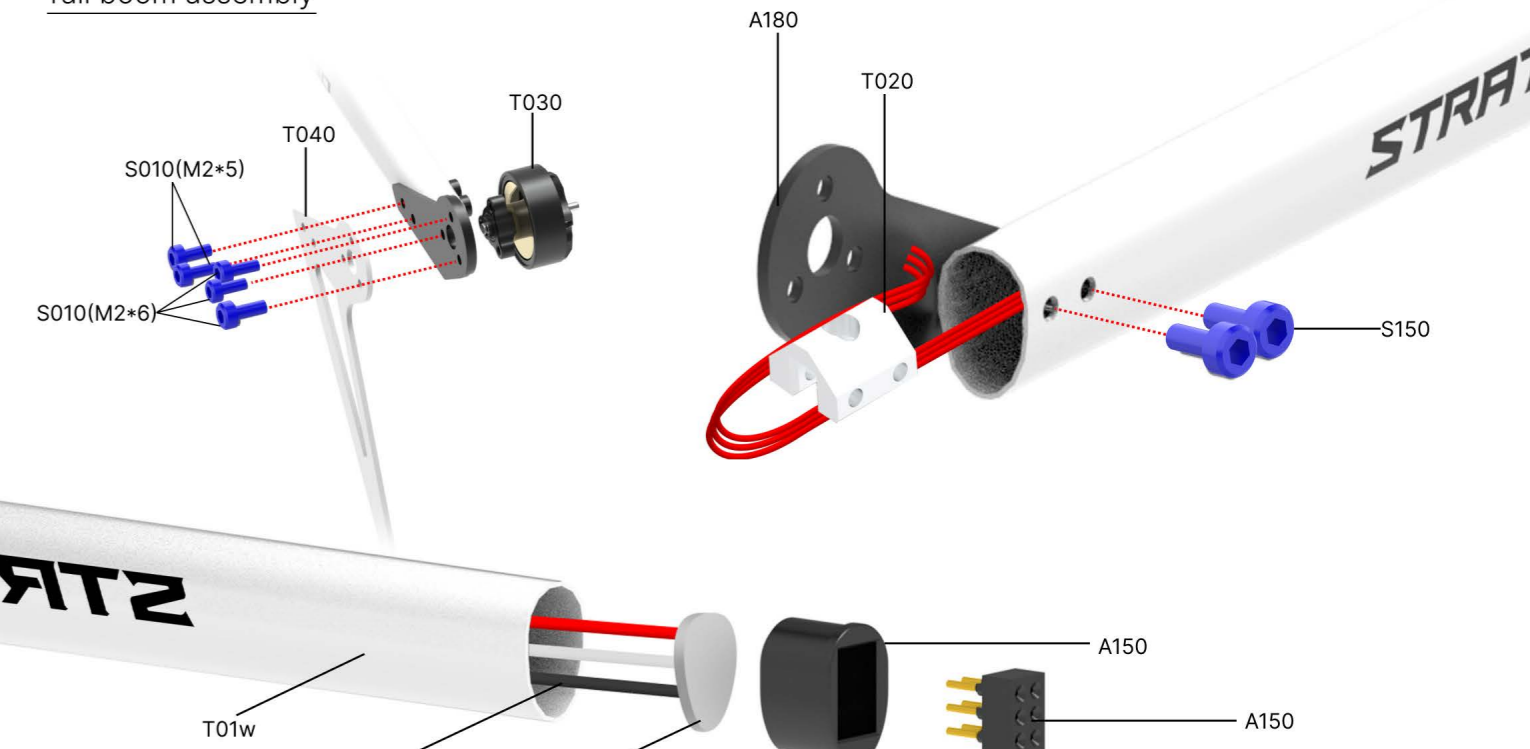













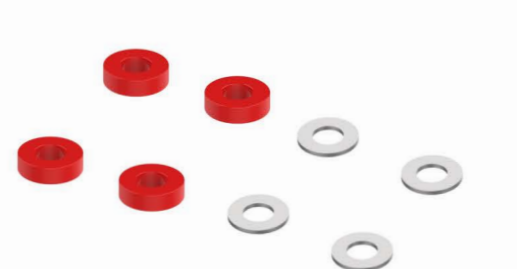







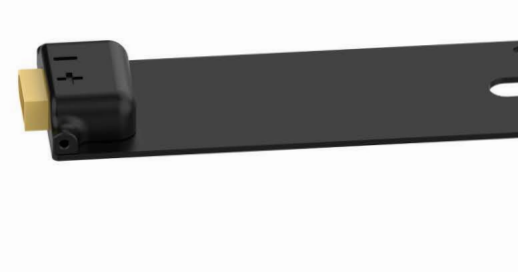







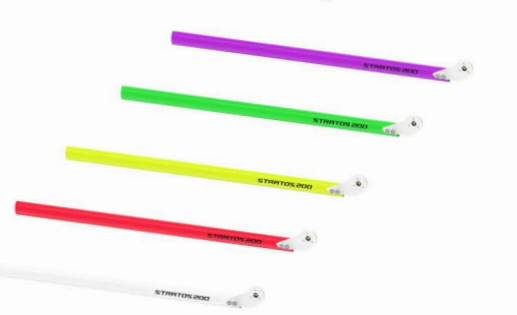
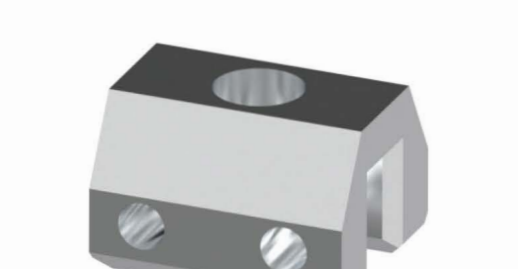















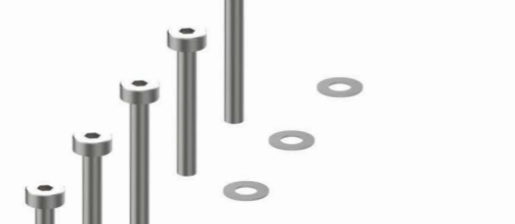



Page18

## Tail boom assembly

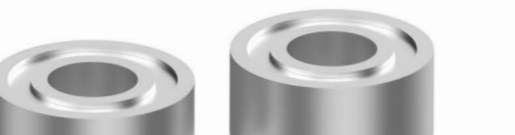

Page20

<p>XL20H010</p>  <p>-1 x Main Hub -4 x Head Damper 90° -1 x M2*10 Screw -1 x M2 Nut</p>	<p>XL20H020</p>  <p>-3 x Spindle shafts -6 x 2*4*0.2 Washers -6 x M2*5 Screws</p>	<p>XL20H030</p>  <p>-4 x Head Damper 90° -2 x 3*6*0.3 Washers -2 x 3*4.5*0.2 Washers</p>	<p>XL20H040</p>  <p>-1 x Main grip -2 x 3*6*2.5 Bearing -1 x 3*5*0.5 Washer -1 x 3*6*2.8 Thrust bearing</p>	<p>XL20H050</p>  <p>-6 x Grip arms -2 x Ball 3.28</p>	<p>XL20H060</p>  <p>-3 x Main shafts</p>	<p>XL20H070</p>  <p>-2 x AZ195 Plastic blades</p>	<p>XL20H080</p>  <p>-1 x Control arm -1 x radius臂 -1 x M2*14Screw -2 x 2*5*2Flanged bearing -1 x 2*4*0.2 Washer -1 x 2*9pin</p>	<p>XL20H090</p>  <p>-2 x Radius arms -2 x 2*9pin</p>	<p>XL20H100</p>  <p>-1 x Swashplate upper -1 x Swashplate outer -2 x 15*21*4 Bearing -1 x 4*12*3 GE4C Bearing -6 x Ball 3.28 -1 x Long Ball 3.28</p>
<p>XL20H120</p>  <p>-2 x AZ195PRO Carbon blades</p>	<p>XL20H130</p>  <p>-4 x Tapered damper -4 x 3*5*0.5 Washers</p>	<p>XL20B010</p>  <p>-1 x Main shaft block -1 x 9mm C clip -1 x 4*9*4 Flanged bearing -1 x 7*9*0.1Washer -1 x 4*9*4Washer</p>	<p>XL20B020</p>  <p>-1 x Center plate -4 x M1.6*4 Screws -4 x M1.6*6 Screws -4 x 1.6*4*0.3 Washers</p>	<p>XL20B030</p>  <p>-1 x Main motor ESC set -1 x Gyro PCB -1 x XT30 Plug -1 x Sticker -1 x Plug seat -1 x XT30 cover -2 x 1.6*5 Screws</p>	<p>XL20B040</p>  <p>-1 x Servo DS4208 -1 x Servo horn -1 x Ball 3.28</p>	<p>XL20B050</p>  <p>-1 x Anti rotation guide Pcb -1 x 6Pin plug -1 x Servo plug -2 x M2*5 Screws</p>	<p>XL20B060</p>  <p>-1 x Tail boom clamp -2 x M2*5 Screws -2 x M2*20 Screws</p>	<p>XL20B070</p>  <p>-2 x Canopy mounts</p>	<p>XL20B080</p>  <p>-2 x XT30 Covers -4 x M1.6*5 Flat head Screws -4 x M1.6*5 Self tap Screws</p>
<p>XL20B090</p>  <p>-1 x Gyro PCB -1 x XT30 Plug -1 x Plug seat -2 x M1.6*5 Screws -1 x XT30 cover -1 x Sticker</p>	<p>XL20B100</p>  <p>-1 x Tail boom clamp plate</p>	<p>XL20B110</p>  <p>-2 x Carbon frame</p>	<p>XL20B120</p>  <p>-2 x ESC Covers -4 x M1.6*6 Screws -4 x 1.6*4*0.3 Washers</p>	<p>XL20B130</p>  <p>-1 x Carbon fiber Battery divider</p>	<p>XL20B140</p>  <p>-1 x Battery clamp post -1 x Silicon tube -2 x 2*4*0.2 Washers -2 x M2*5 Screws</p>	<p>XL20B150/R/Y/G</p>  <p>-1 x Landing gear (W/Y/G) -4 x M2*5 Screws</p>	<p>XL20B160</p>  <p>-1 x Motor rotor</p>	<p>XL20T010/W/R/Y/P/G</p>  <p>-1 x Tail boom (B/W/R/Y/P/G)</p>	<p>XL20T110/W/R/Y/P/G</p>  <p>-1 x Tail boom (B/W/R/Y/P/G) -1 x 3Pin silicon wire -1 x 6Pin plug -1 x Tail motor mount PCB -1 x Plug seat -2 x M2*3 Screws</p>
<p>XL20T020</p>  <p>-1 x Tail fin mount</p>	<p>XL20T030</p>  <p>-1 x Tail motor -1 x Tail motor PCB -3x M2*6 Screws</p>	<p>XL20T040/Y/P/G/R</p>  <p>-1 x Tail fin (W/Y/P/G/R)</p>	<p>XL20T050</p>  <p>-2 x AZ45 tail blade -4 x M1.6*8 Screws -4 x 1.6*4*0.3 Washers</p>	<p>XL20A010</p>  <p>-6 x Ball 3.28</p>	<p>XL20A030</p>  <p>-2 x Long Ball 3.28</p>	<p>XL20A040</p>  <p>-4 x Linkages</p>	<p>XL20A050</p>  <p>-2 x 9mm C clips -2 x 7*9*0.1 Washers</p>	<p>XL20A060</p>  <p>-4 x Servo horn</p>	<p>XL20A120</p>  <p>-4 x Canopy grommet</p>
<p>XL20A130</p>  <p>-1 x Blade holder</p>	<p>XL20A150</p>  <p>-1 x 6Pin plug -1 x Plug seat -1 x Plug PCB</p>	<p>XL20A170</p>  <p>-1 x 3Pin silicon wire</p>	<p>XL20A180</p>  <p>-2 x Tail motor mount PCB</p>	<p>XL20S010</p>  <p>-5 x M2*5 Screws -5 x M2*6 Screws</p>	<p>XL20S020</p>  <p>-5 x M2*12 Screws -5 x M2 Nuts</p>	<p>XL20S030</p>  <p>-5 x M2*10 Screws -5 x M2 Nuts</p>	<p>XL20S050</p>  <p>-5 x M2*14 Screws -5 x 2*4*0.2 Washers</p>	<p>XL20S060</p>  <p>-5 x M2.5*12 Screws</p>	<p>XL20S070</p>  <p>-10 x M1.6*4 Screws</p>
<p>XL20S120</p>  <p>-5 x M2*20 Screws</p>	<p>XL20S140</p>  <p>-5 x M3*4 Set screws</p>	<p>XL20S150</p>  <p>-10 x M2*3 Screws</p>	<p>XL20BB010</p>  <p>-2 x 3*6*2.5 Bearings</p>	<p>XL20BB020</p>  <p>-2 x 3*6*2.8 Thrust bearings -2 x 3*5*0.5 Washers</p>	<p>XL20BB030</p>  <p>-2 x 2*5*2 Flanged bearings</p>	<p>XL20BB060</p>  <p>-2 x 4*9*4 Flanged bearings</p>	<p>XL20BB070</p>  <p>-2 x 4*9*4 Bearings</p>	<p>XL20C010/020/030/040</p>  <p>-1 x Canopy (R/G/O/P)</p>	